

CIVIC PLAZA

PROCESS BOOK BY CALE MOOTH

DIRECTION FINDING • PUBLIC ART INSTALLATION • EXPERIENCE DESIGN

This project reimagines a multi-purpose civic space by introducing signage & direction finding, a public art installation, and recognition of the people that lived in the area long before the city was established.

AUDIENCE & CONTEXT

This refreshed civic space targets the citizens of Murfreesboro, Tennessee helping them becoming more familiar with their city and local resources.



TABLE OF CONTENTS

Research & Analysis 3

Design Exploration 9

Solution 15



RESEARCH & ANALYSIS



SPACE STUDY



Civic Plaza sits just off the square in Murfreesboro, TN. Anchored by a large open space that doubles as an amphitheater, the space also includes a library, a park, and city hall.

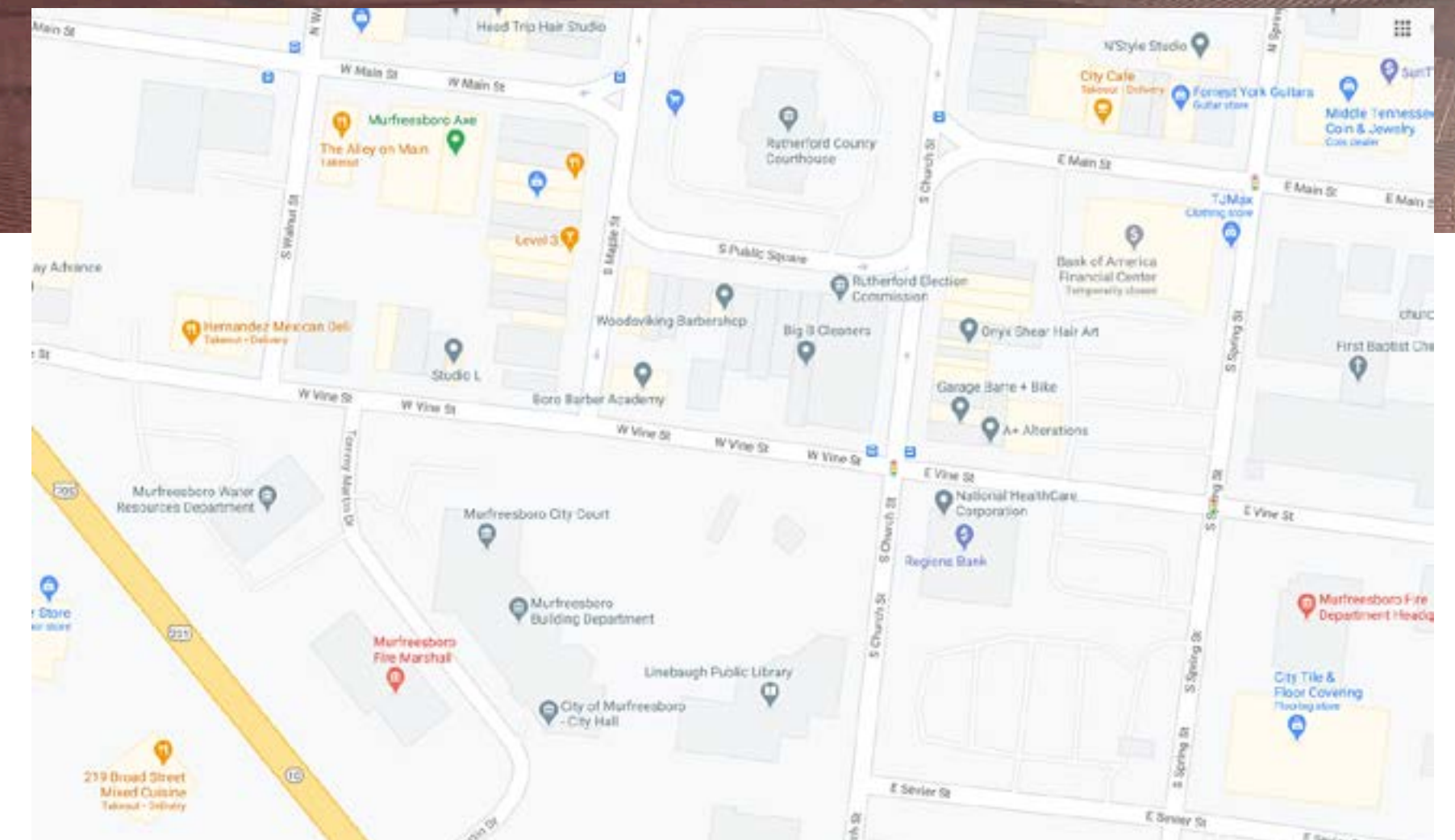



Multiple views of the library including, front, back, pick-up, and drop-off areas.

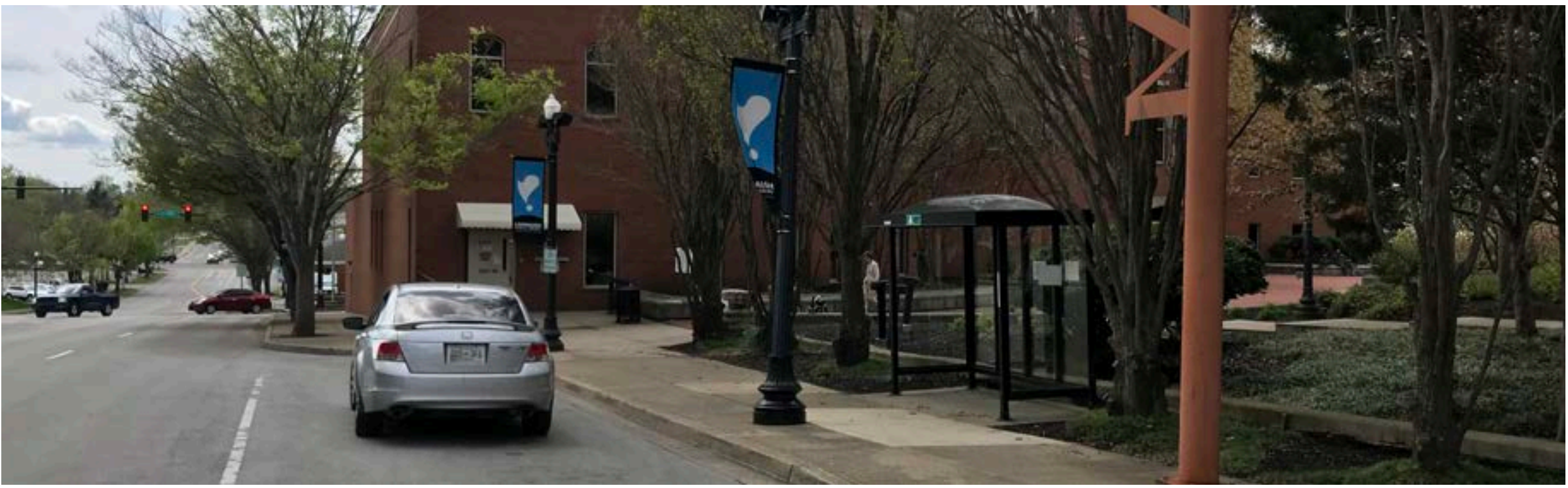

EXISTING SIGNAGE STUDY



EXISTING SIGNAGE STUDY

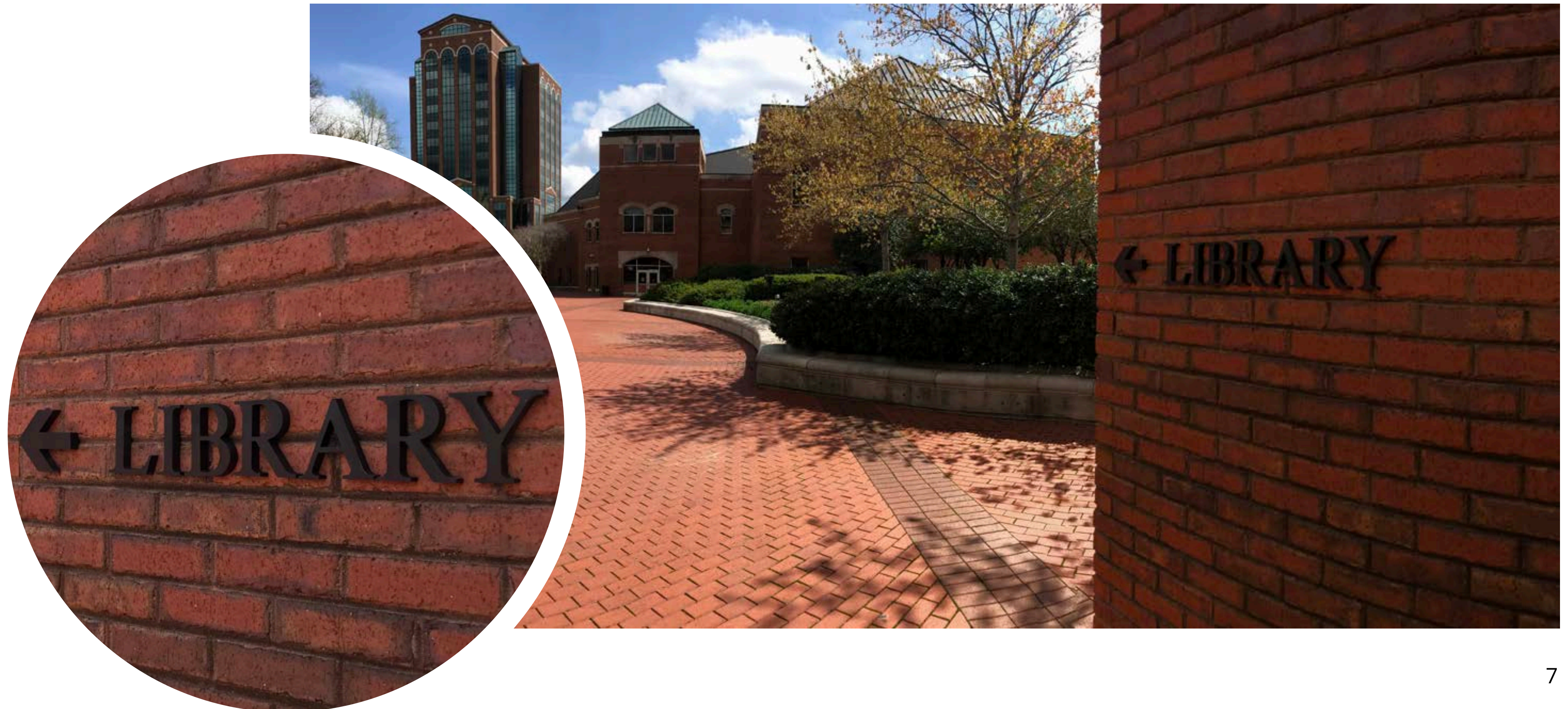
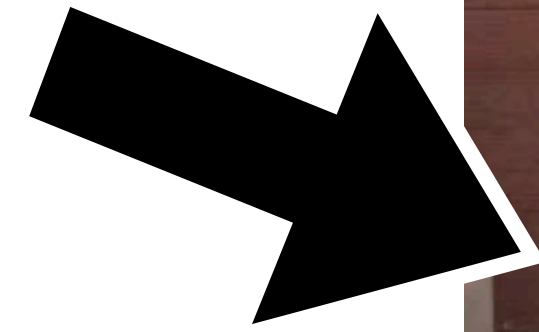

SURVEY RESULTS

How would you describe your experience when navigating Civic Plaza?

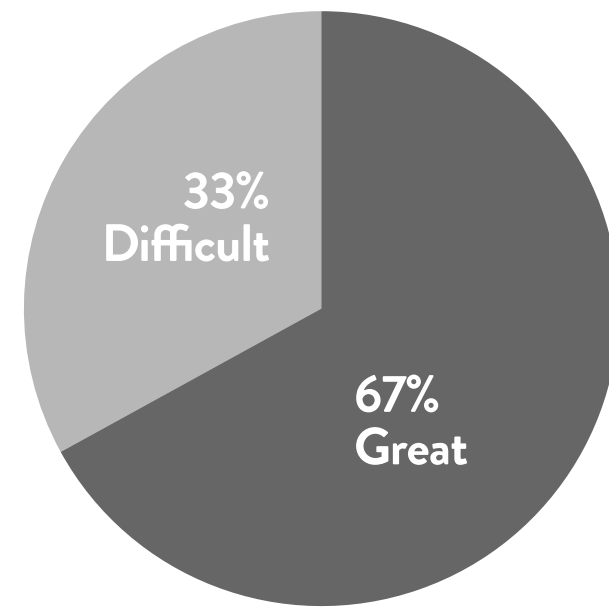

67% Great. I always find what I'm looking for.

0% Fair. It takes extra effort, but I eventually find what I'm looking for.

33% Difficult. Finding what I'm looking for at Civic Plaza is a challenge.

Have you ever asked patrons or employees for help when navigating Civic Plaza?

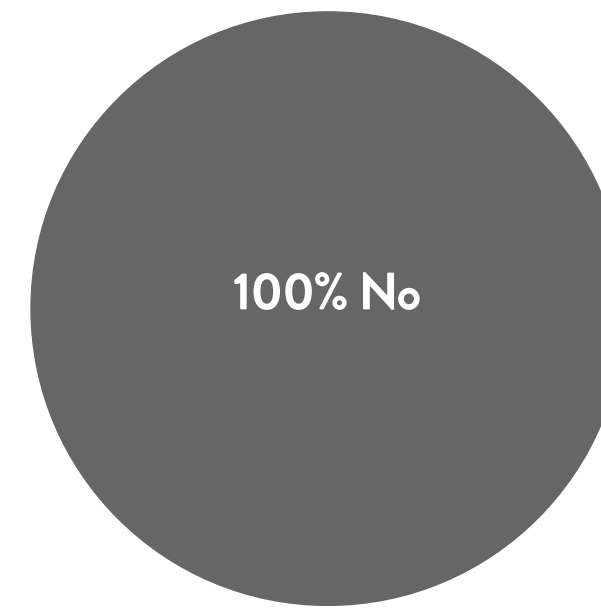

100% No

0% Yes

Is the signage at Civic Plaza helpful?

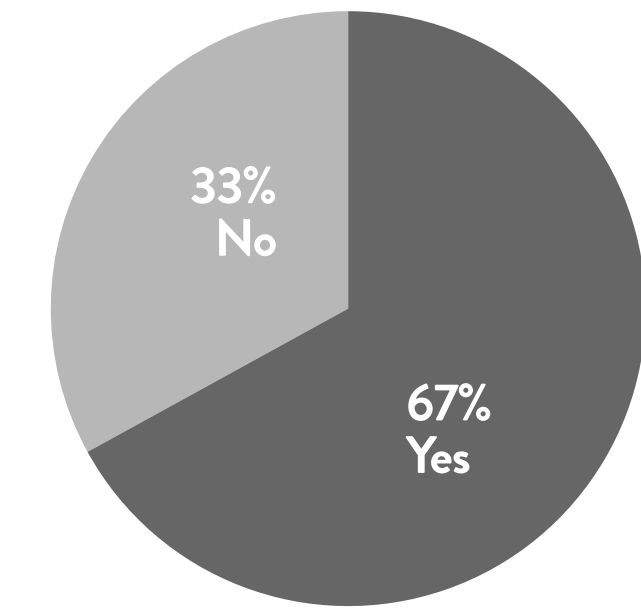

67% Yes

33% No

“There could be more signs available!
Especially once one is parked in the parking garage, it's hard to know where to go from there.”

Which services do you use when visiting Civic Plaza?

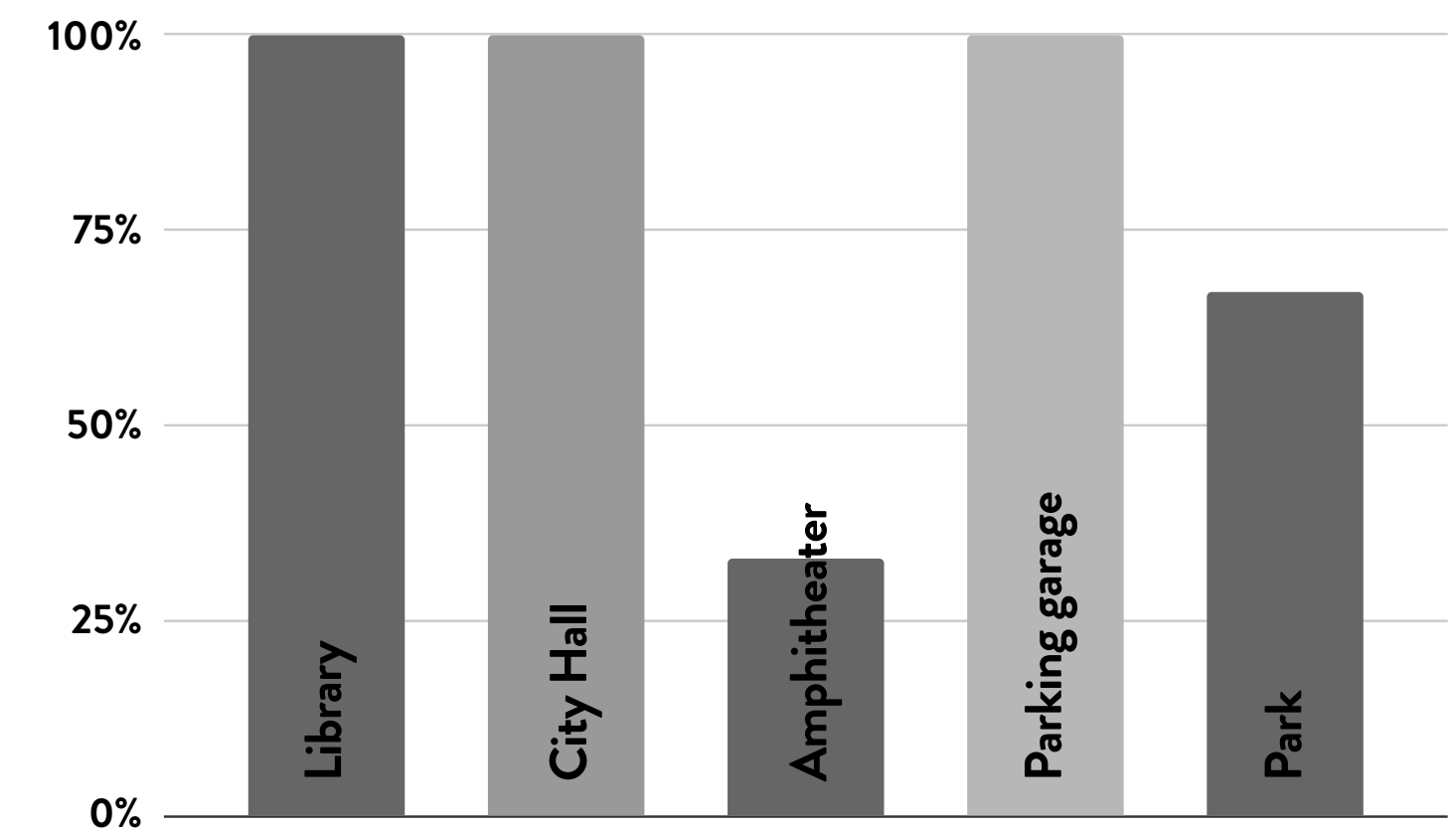

DESIGN EXPLORATION



AESTHETIC OPTIONS



COLOR PALLET

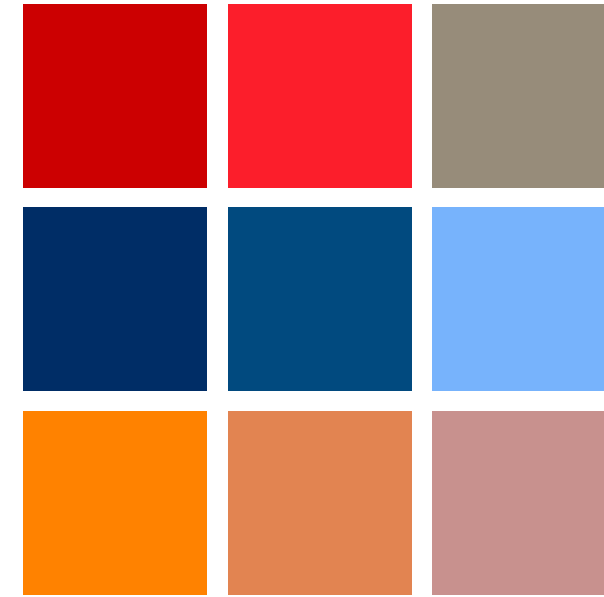

SYMBOLS



COLOR PALLET



SYMBOLS



COLOR PALLET

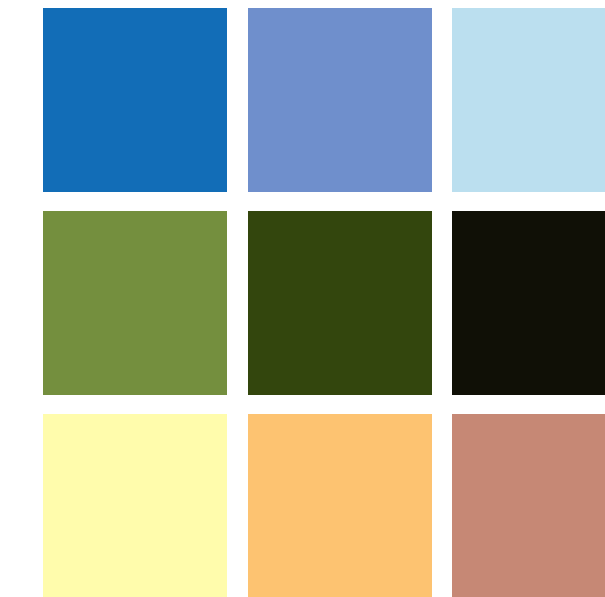

SYMBOLS

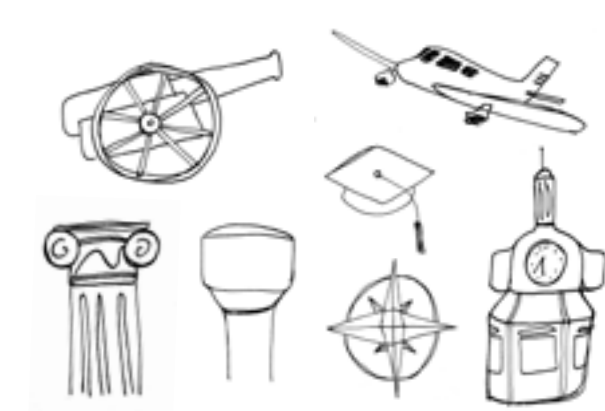

FINAL AESTHETIC CHOICE



image source: tn.gov



image source: tn.gov



image source: tn.gov



image source: fineartamerica.com



COLOR PALETTE



SYMBOLS



SIGNAGE EXPLORATION

This concept references limestone, the prominent rock found in Middle Tennessee. Limestone is paired with anodized aluminum which is adorned with a glyph representing cultural significance to the area.

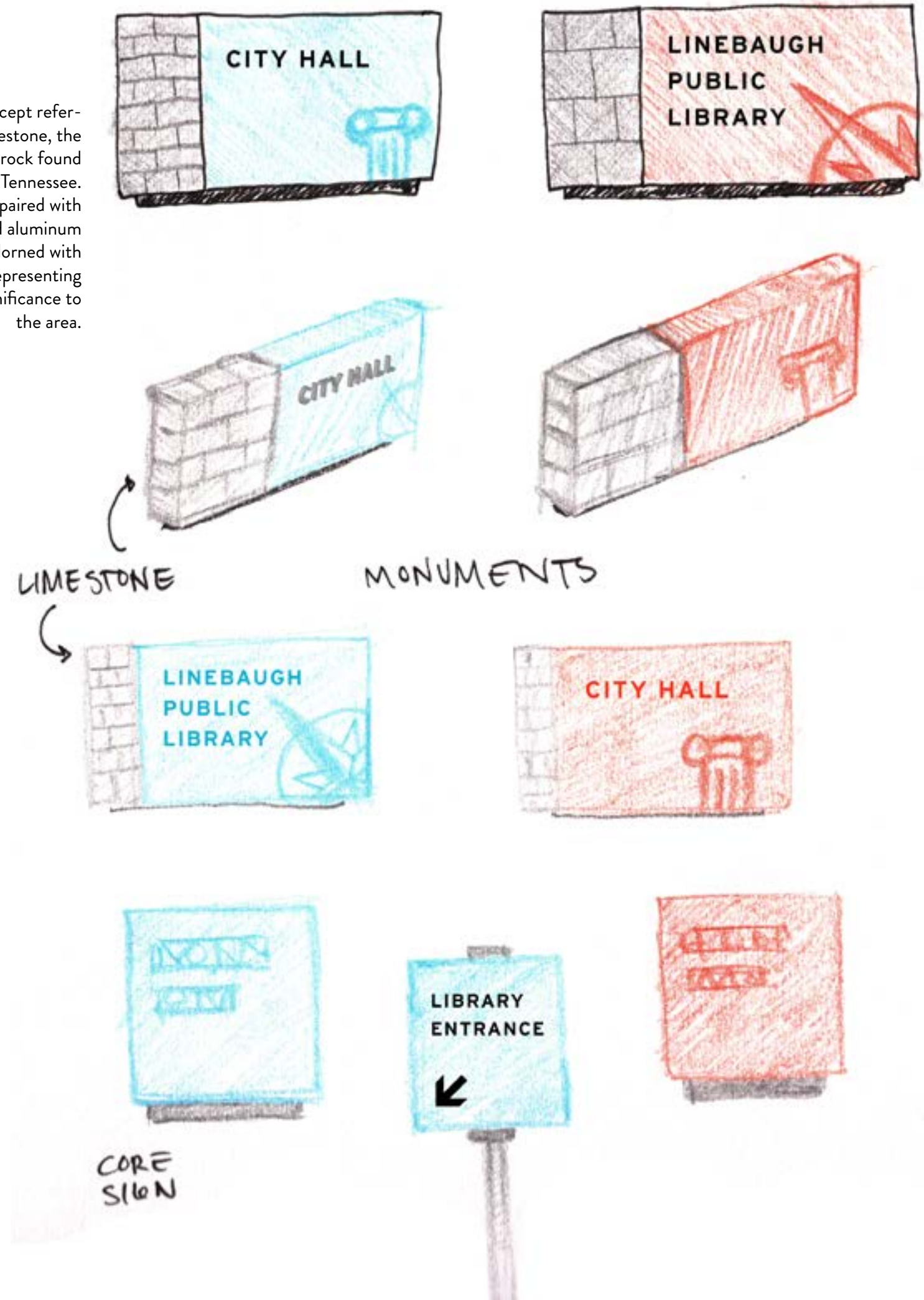

Continuing the limestone theme, this version of a monument is constructed of one large slate of limestone.

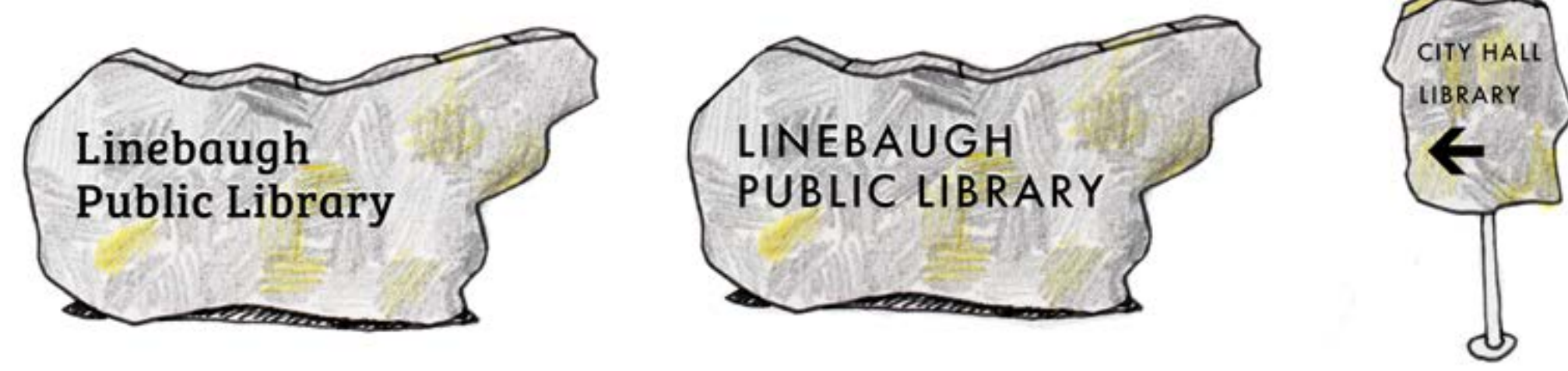

This concept utilizes reclaimed barn wood referencing barns and other wood farm structures that are present across the Middle Tennessee countryside. Longevity and maintenance would need to be considered with this material.

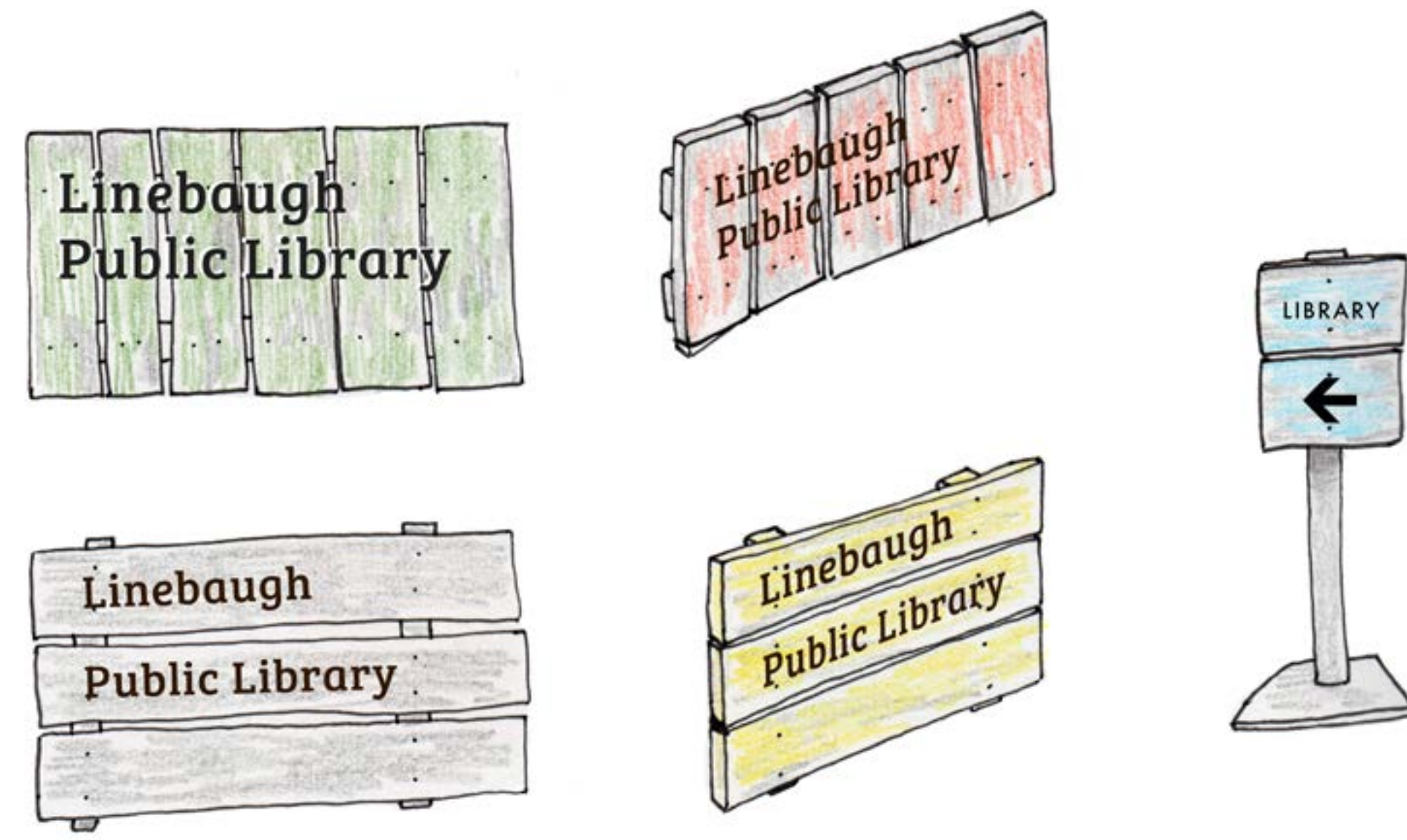

REFINED SIGNAGE EXPLORATIONS

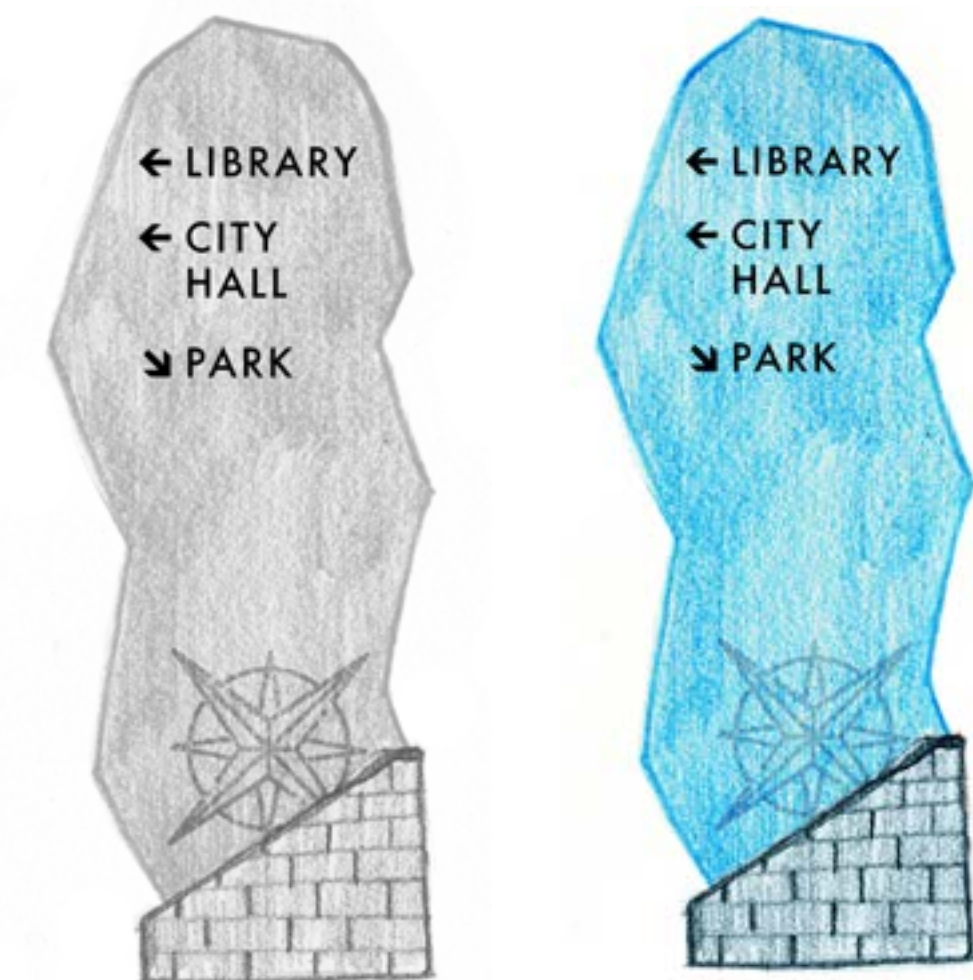
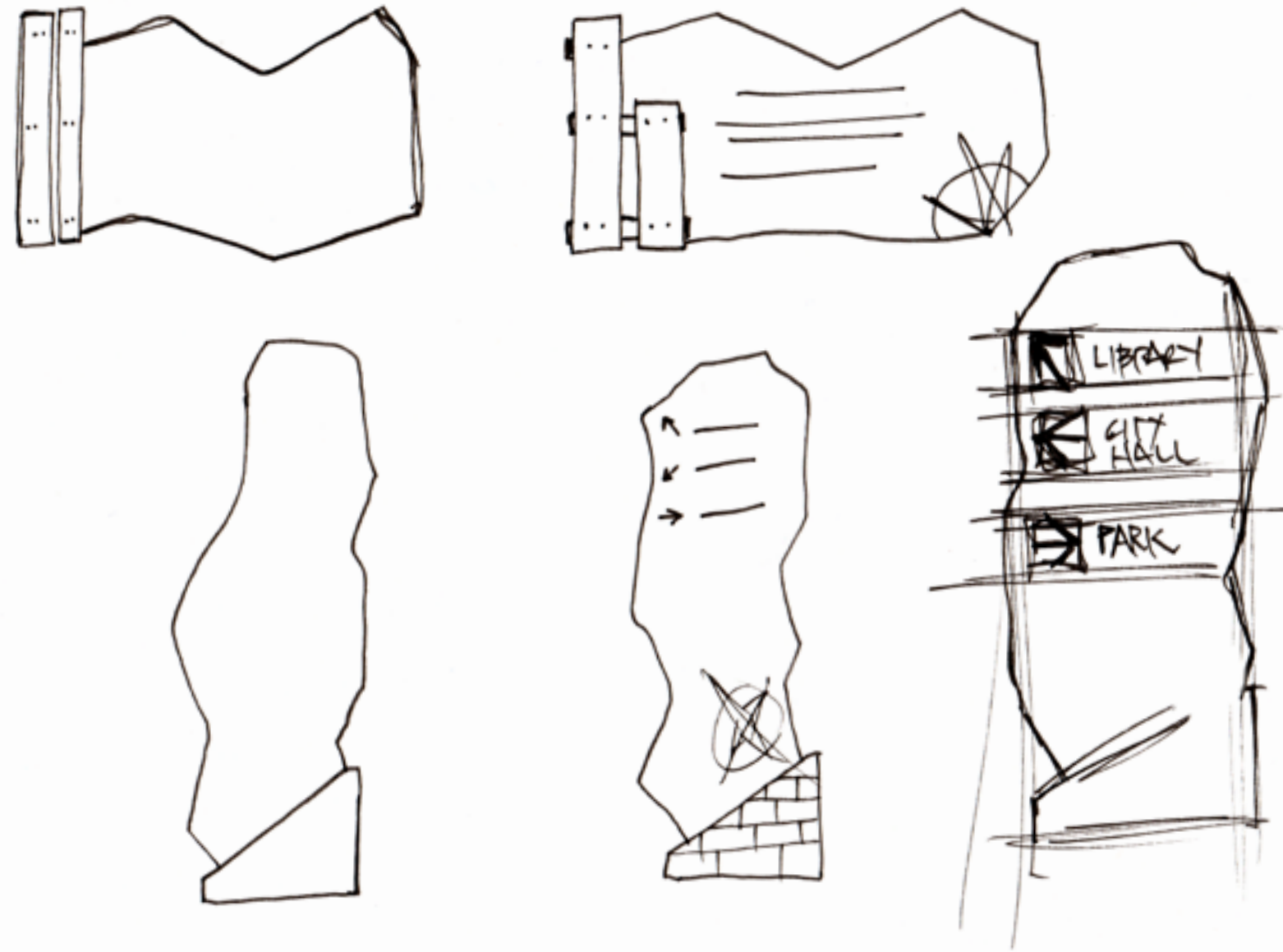
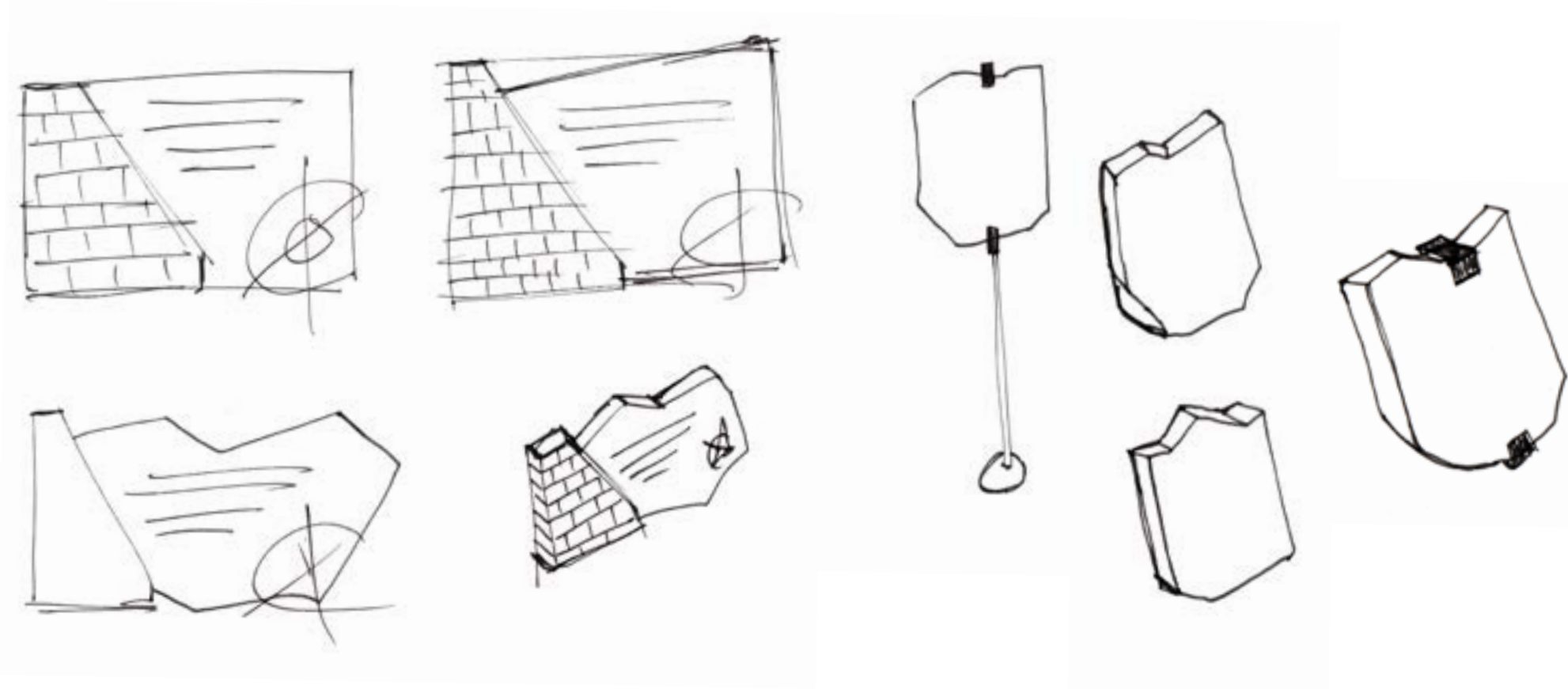

Combining several elements from previous concepts, this version continues to focus on the limestone theme. Each sign features a limestone brick base. The signs themselves take on the shape of a limestone slab, but are constructed from anodized aluminum or plastics.

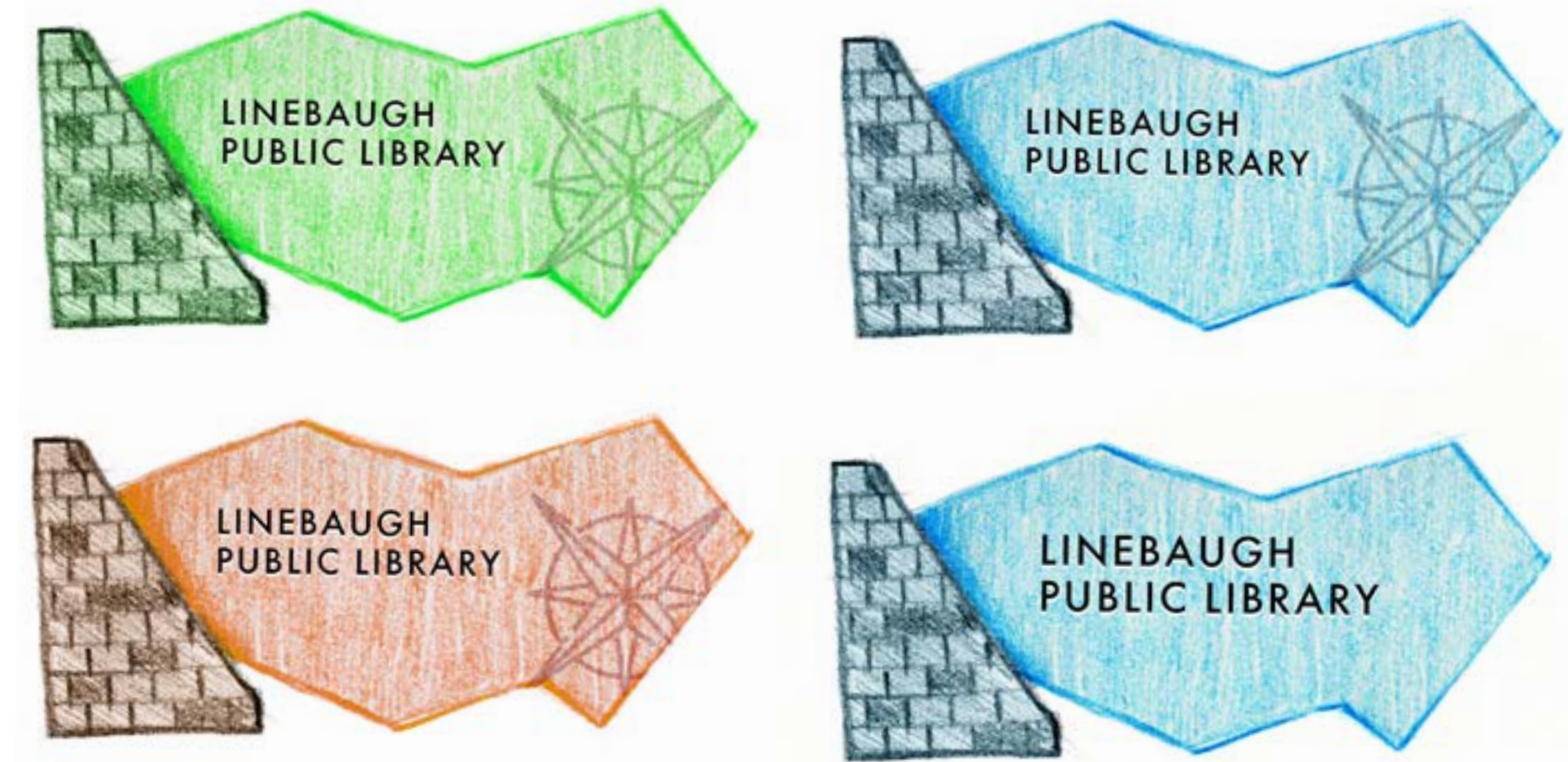

TYPOGRAPHIC EXPLORATION

LINEBAUGH
PUBLIC LIBRARY

Adobe Caslon

**LINEBAUGH
PUBLIC LIBRARY**

Interstate Bold

**LINEBAUGH
PUBLIC LIBRARY**

Bree Serif Bold

Linebaugh
Public Library

Adobe Caslon

LINEBAUGH
PUBLIC LIBRARY

Rothwood Book

**Linebaugh
Public Library**

Bree Serif Bold

Linebaugh
Public Library

Bell Centennial Std

Linebaugh
Public Library

Rothwood Book

LINEBAUGH
PUBLIC LIBRARY

Futura PT Medium



FINAL SOLUTION



WAYFINDING EXAMPLES

Directional Sign

Directional signage is placed at key points along primary paths to assist users in finding their desired destination.



Core Sign

Core signs function at close distances, typically mounted adjacent to doorways to mark room numbers or provide additional direction.

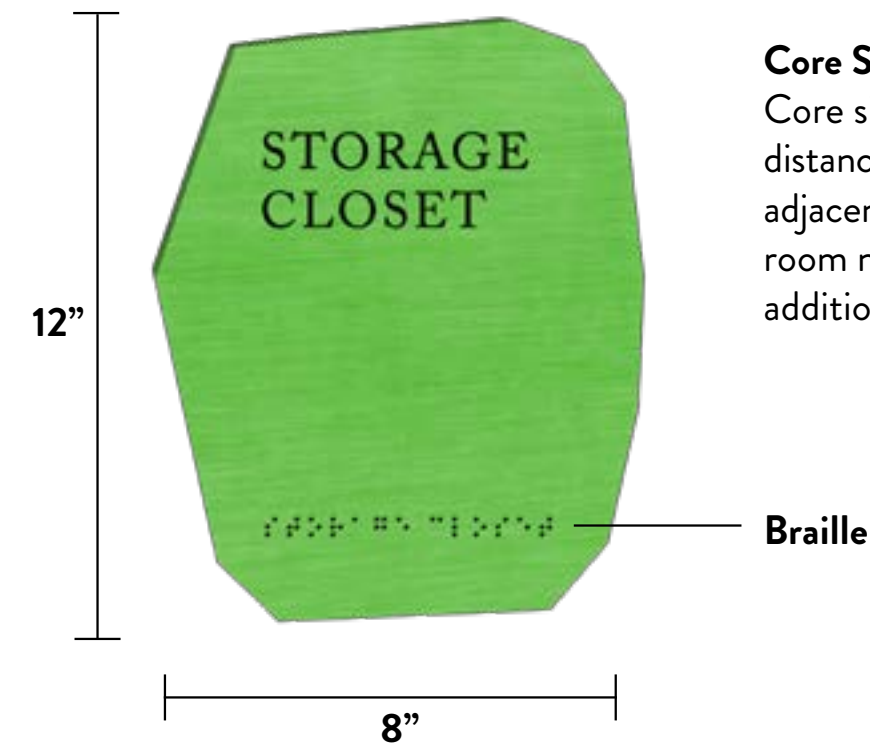

Monument Sign

These large signs are placed outside of public buildings such as city hall and the library to mark both the building's name and entrance

Compass

The compass references the significance of Middle Tennessee geography, including its status as the geographic center of the state. The compass also points to adventure in learning and reading facilitated by the library.

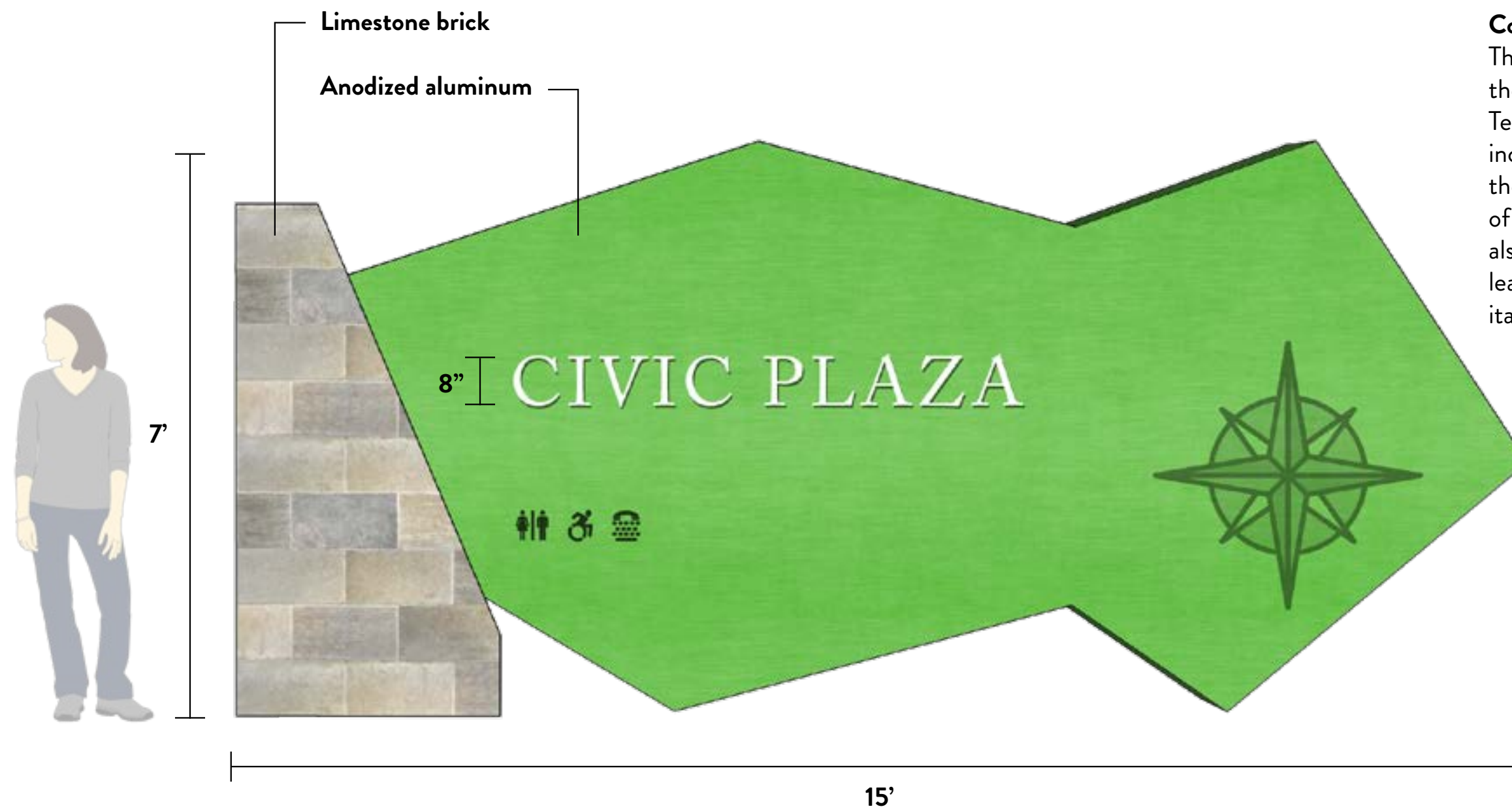

PATHWAY AND SIGN PLACEMENT DIAGRAMS



- PEDESTRIAN FLOW FROM SURFACE STREETS TO CIVIC PLAZA
- PEDESTRIAN FLOW FROM PARKING GARAGE TO CIVIC PLAZA
- PEDESTRIAN FLOW FROM PARKING GARAGE TO OTHER VENUES
- AUTOMOBILE FLOW TO PARKING GARAGE
- > ORIGIN
- DESTINATION

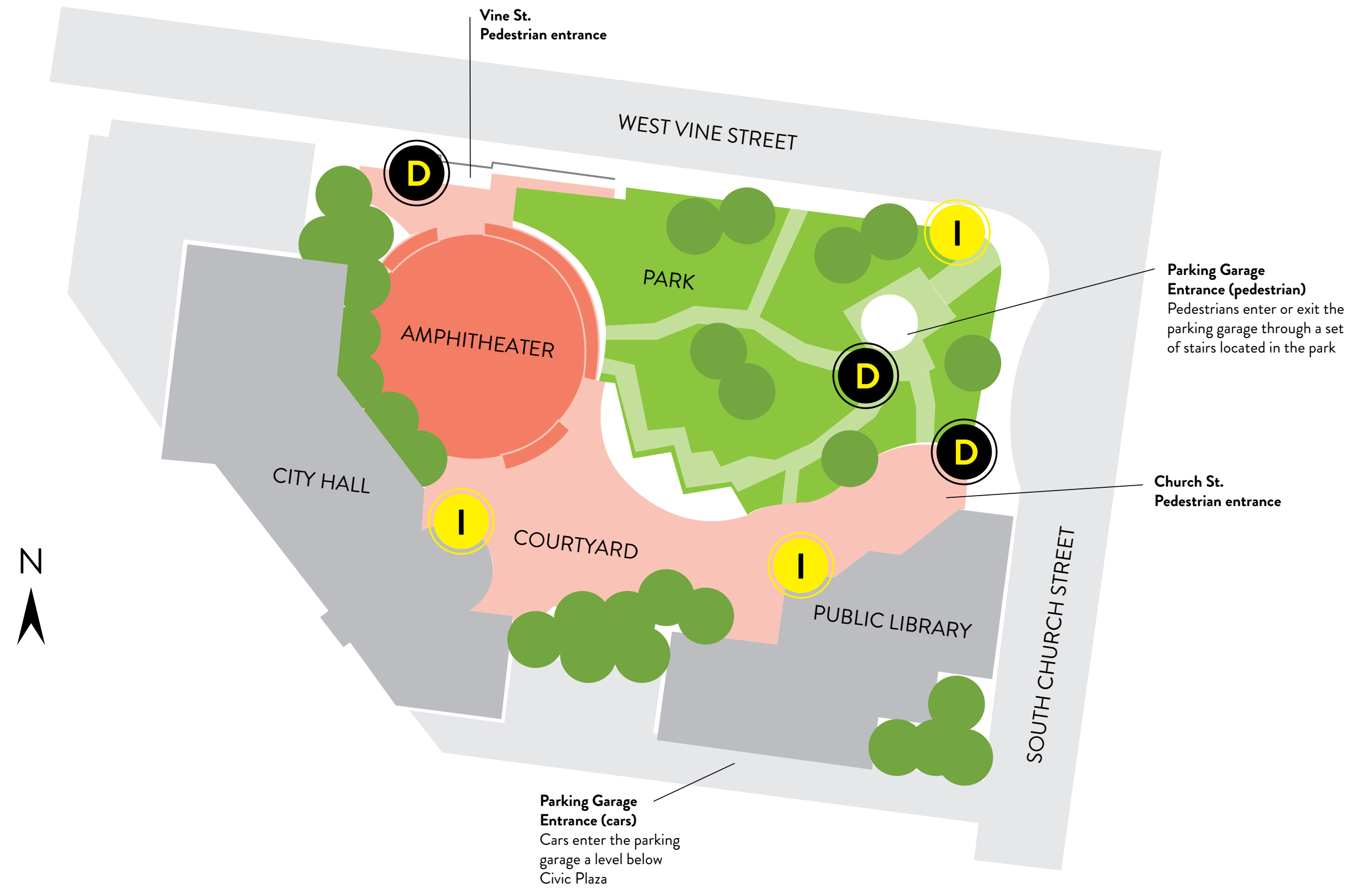

- I** IDENTITY SIGNAGE PLACED AT THREE PRIMARY DESTINATION POINTS
- D** DIRECTIONAL SIGNAGE PLACED AT THREE PRIMARY JUNCTION POINTS







calemooth.com • csmooth@gmail.com

